

CHROMSYMP. 184

FAST “FLUIDIC LOGIC” INJECTION AT PRESSURES UP TO 25 BAR IN HIGH-SPEED CAPILLARY GAS CHROMATOGRAPHY

C.P.M. SCHUTJES and C.A. CRAMERS*

Eindhoven University of Technology, Laboratory of Instrumental Analysis, P.O. Box 513, 5600 MB Eindhoven (The Netherlands)

and

C. VIDAL-MADJAR and G. GUIOCHON

École Polytechnique, Laboratoire de Chimie Analytique Physique, Route de Saclay, 91128 Palaiseau Cedex (France)

SUMMARY

The fast “fluidic logic” injection system developed by Gaspar and co-workers for use in high-speed capillary gas chromatography (GC) was evaluated at pressures between 4 and 25 bar. When correctly controlled, the fluidic device performed well. A sample band width of 5 msec was normally obtained, for all compounds injected.

The fluidic logic injector enabled precise H versus \bar{u} studies on two 8 m \times 50 μ m I.D. capillary GC columns, coated with cross-linked OV-1, to be made. For *n*-pentane, which was not retarded, a maximum of 400,000 plates were obtained, at a column inlet pressure of 20.0 bar. About 180,000 plates were obtained for *n*-dodecane, having a capacity ratio of 4.

The observed plate height curves were compared with the Golay–Giddings plate height model. Good agreement between the measured and theoretical plate numbers was found, even for the unretained compound, thus demonstrating the absence of dead volumes in the fluidic injector design.

INTRODUCTION

In capillary gas chromatography (GC) a greatly increased speed of analysis can be obtained, while preserving the resolution, by reducing the dimensions of the capillary column. However, such columns are known to require injection and detection equipment with very low time constants.

In 1977, Gaspar and co-workers^{1–3} investigated fast chromatography on 1-m capillary columns of 65 μ m I.D., with about 10^4 theoretical plates. Using an injector based on a “fluidic logic” device, they achieved reproducible introduction of samples within a few milliseconds, at column inlet pressures up to 4 bar. Schutjes *et al.*⁴ recently described fast separations of complex mixtures on 8 m \times 50 μ m I.D. columns, having about 10^5 theoretical plates and requiring an inlet pressure of about 10 bar. A conventional split-mode injector was used for sample introduction. Plate height studies on

these columns appeared to be biased by the time constants of the chromatographic system, resulting in a significant peak broadening for compounds eluted at a low capacity ratio.

Recently, the fluidic logic injector design of Gaspar and co-workers was tested at pressures between 4 and 25 bar. The results are presented in this paper. Plate height curves that were obtained with the fluidic logic injector for two 50 μm I.D. capillary columns coated with a non-polar, cross-linked stationary phase are discussed.

EXPERIMENTAL

Fluidic logic injection

A Model 191445/191453 monostable OR/NOR fluidic logic gate (Corning, Corning, NY, U.S.A.) was used. A schematic drawing is presented in Fig. 1. Briefly, the gate contains two flow paths, one connected to the capillary column and the other to the atmosphere. When the stream of gas containing the sample passes through the fluidic gate under conditions of turbulent flow, the fluid becomes attached to the column wall by the Coanda effect. As a result, the entire flow is preferentially directed to outlet O_2 , even though both outlets are kept at the same pressure. To prevent the sample from entering the column by diffusion, a small flow of carrier gas is directed towards vent V_1 , thus purging the column inlet. When pressure is applied to the command input port, Co, of the gate, the flow direction is changed until the pressure is removed. Owing to the low inertia of the system, flow path switching is accomplished within 1 msec.

Each flow path is connected to the atmosphere by a vent, which provides a stable turbulent flow inside the fluidic gate, even if large restrictions are present at the outlets of the gate. Owing to the presence of the vent, the sample is necessarily split.

A fluidic device requires a small pressure drop (<0.5 bar) for correct operation, whereas a capillary column may need an inlet pressure of several bars. The fluidic device must therefore be enclosed inside a pressurised vessel, as has been shown by Gaspar *et al.*¹ The vessel used in our experimental work is shown in Fig. 2. This vessel consists of two brass parts which are firmly clamped together with six steel bolts of 6 mm diameter. A PTFE O-ring ensures a reliable, heat-resistant seal. Inside the vessel, a volume of 20 ml is available to the pressurizing gas.

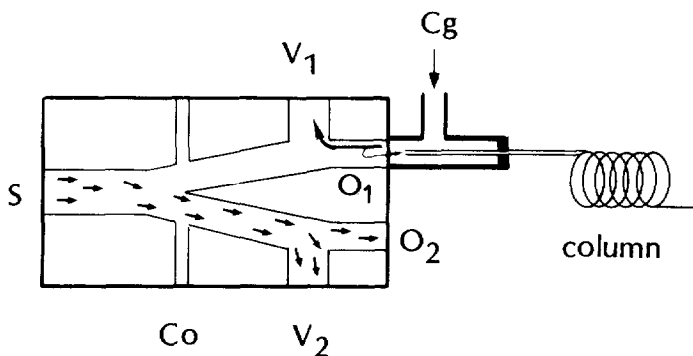

Fig. 1. Schematic drawing of the fluidic gate. S = Sample inlet; O = outlet; V = vent; Co = command port; Cg = carrier gas inlet.

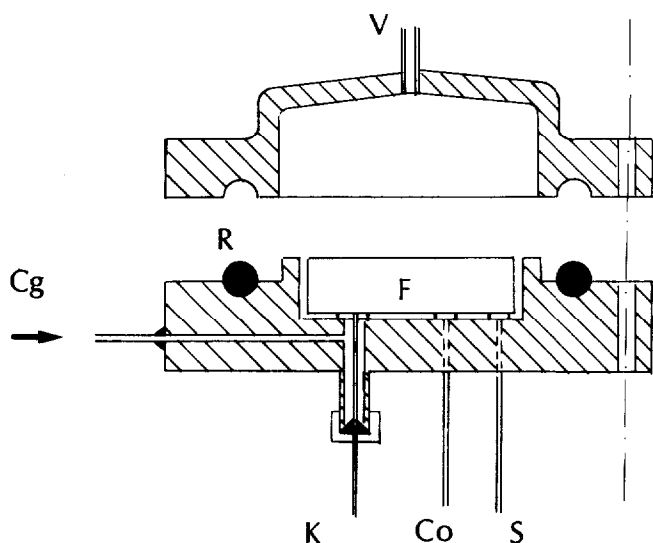

Fig. 2. Scheme of the pressurized vessel. F = Fluidic device ; R = O-ring; V = vessel outlet; K = capillary column; Cg = carrier gas; Co = command signal; S = sample gas.

The gases required for the actuation of the fluidic gate are supplied through channels with diameters of 1.6 mm, drilled in the bottom part of the vessel. The column is positioned as close as possible to the outlet of the fluidic gate through a channel of similar dimensions, which in addition is connected to the carrier gas supply line. The vessel is mounted inside the GC oven, so that the fluidic gate is operating at the oven temperature.

A schematic diagram of the gas circuits is given in Fig. 3. Pressure regulators (Veriflo, Richmond, CA, U.S.A.; Model IR 503) and fine metering valves (Nupro,

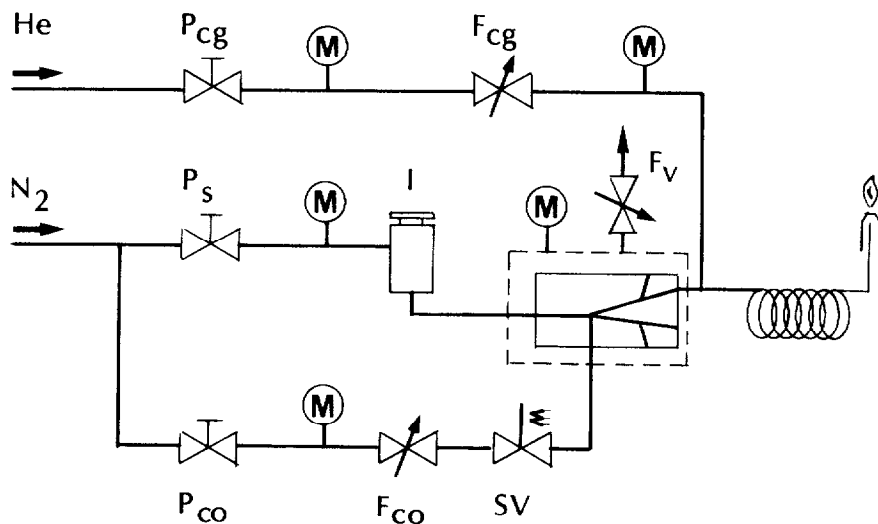

Fig. 3. The gas circuits. P = Pressure controller; F = fine metering valve; M = manometer; SV = solenoid valve; I = injector; cg = carrier gas; co = command; s = sample gas; v = vessel outlet.

Willoughby, OH, U.S.A.; Model S) are incorporated in all the circuits to provide both pressure and flow control. A flow of nitrogen is continuously applied to the inlet port of the fluidic device and leaves through the outlet O_2 and the vent V_2 .

The metering valve, F_V , at the outlet of the vessel is adjusted to a flow of 1.5 l/min, thus ensuring turbulent flow conditions inside the fluidic gate. Liquid samples of 1–5 μl are introduced by syringe injection into a laboratory-built injector and are evaporated at 280°C. The resulting vapour band, having a duration of several seconds and showing an exponential decay of concentration with time, is carried to the fluidic gate by the above-mentioned nitrogen flow. By briefly actuating the solenoid valve (HUBA, Würenlos, Switzerland; Model 210), which is placed in the command line, the pressure at the command port of the fluidic gate is briefly raised. A small band of sample is then introduced into the column. The column outlet is positioned 1 mm below the flame of the flame-ionization detector (Carlo Erba, Milan, Italy), which is heated at 220°C. Helium is used as the carrier gas.

Detection and data handling

The detector signal is amplified by a Model 427 fast current amplifier (Keithley Instruments, Cleveland, OH, U.S.A.) with a selectable time constant. The signal is then digitized, the sampling rate being controlled by an adjustable external clock². The digitized data are stored and processed on a Model 21M30 minicomputer system (Hewlett-Packard, Palo Alto, CA, U.S.A.). This system is also used to control the solenoid valve in the command line. Owing to inertia, the solenoid has to be actuated for a minimum of 25 msec to ensure opening of the valve. A period of 30 msec was used in all our experiments, giving an injection band with a standard deviation of 5 msec (Fig. 4).

Column preparation

Borosilicate columns (Duran 50; Schott, Wertheim, F.R.G.) with I.D. 50 μm and O.D. 0.7 mm were drawn with a laboratory-built precision drawing machine. Fused silica tubing of 50 μm I.D. was obtained from S.G.E. (Melbourne, Australia). The

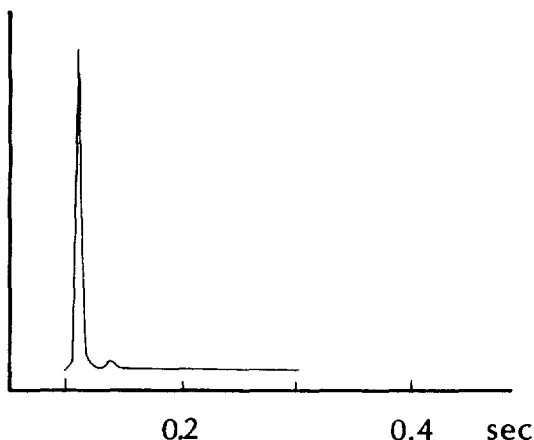

Fig. 4. *n*-Pentane peak with a standard deviation of 4.5 msec, obtained with the fluidic injector at 20.3 bar, on a 60 cm \times 50 μm I.D. fused-silica column.

precise inner diameter was calculated after weighing the amount of mercury that could be introduced into a piece of column of known length.

Prior to coating, the columns were rinsed with methanol and dichloromethane, then dried by passing nitrogen through them. A solution containing approximately 0.5% (v/v) of OV-1 and 0.1 mg/ml of dicumyl peroxide (Merck-Schuchardt, Munich, F.R.G.) in *n*-pentane was introduced by gas pressure. A static coating method was used. The stationary phase was then cross-linked by heating the columns at 160°C for 90 min, while maintaining a nitrogen flow. Finally, the columns were rinsed with dichloromethane and *n*-pentane.

RESULTS AND DISCUSSION

The fluidic injector was tested at several pressure levels between 4 and 25 bar. At each pressure level similar results were obtained. It was found that the carrier gas pressure, P_{cg} , must be maintained at a value slightly above the vent pressure. The resulting purge flow is directed via O_1 towards the vent V_1 (Fig. 1) and is best controlled with the fine metering valve F_{cg} (Fig. 3).

This purge flow serves a double purpose. First, the column is guarded against compounds that are diffusing from the flow path O_2 or from the gas inside the vessel. Second, immediately following the injection of the sample, the large spaces near the inlet of the column are purged very quickly. This minimizes dead volume effects which could give rise to broadening and tailing of the peaks. Large purge flow-rates were observed to inhibit injection of the sample and therefore must not be used.

When studying the command pressure, P_{co} , asymmetric peaks and multiple injections were observed whenever excessive amounts of nitrogen were allowed to pass into the pressurized vessel. The pressure inside the vessel was then observed to rise, thus disturbing the flow pattern inside the gate. The use of a flow restriction in the command line is therefore recommended, and P_{co} should not be made unnecessarily high.

When the fluidic gate is prepared for operation, the valve F_{cg} is closed. The sample gas pressure, P_s , is then raised to the desired working pressure, valve F_v is opened and P_{cg} is adjusted to 0.3 bar above P_s . The valve F_{cg} is then gradually opened until *n*-pentane, which is slowly injected into the vapourizing injector, stops diffusing into the capillary column and no longer contributes to the detector signal. The command pressure, P_{co} , is preferably set to 0.5 bar above P_s .

Once properly adjusted, the parameters controlling the fluidic injector remained very stable, ensuring reproducible results. The injector performed very well at all the pressures studied, as is demonstrated in Fig. 4. The symmetrical peak with a standard deviation of 4.5 msec was obtained for *n*-pentane at 20.3 bar on a 60 cm \times 50 μ m I.D. fused-silica column. Similar results were obtained for alkanes with higher boiling points, up to *n*-tetradecane.

Employing the fluidic injector, plate height curves were assessed at 120°C for an 8.0 m \times 47.1 μ m I.D. borosilicate glass column with a film thickness of 0.075 μ m, and at 106°C for a 10.14 m \times 55.4 μ m I.D. fused-silica column with a film thickness of 0.06 μ m. Helium was used as the carrier gas. The compounds studied were *n*-pentane, having an estimated capacity ratio of $k = 0.05$, *n*-undecane, with $k = 2$, and *n*-dodecane, with $k = 4$. The time constant of the electrometer was set at 10 msec for *n*-pentane

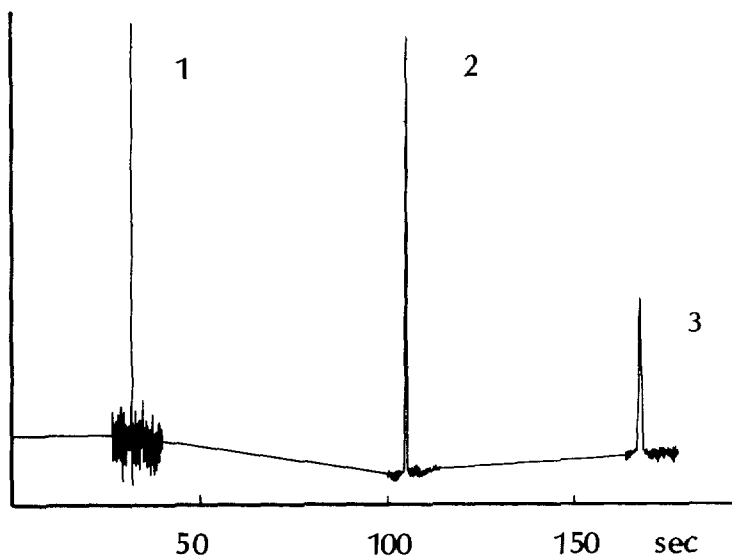

Fig. 5. Typical chromatogram, obtained with the fluidic logic injector at 10 bar, showing (1) *n*-pentane, (2) *n*-undecane and (3) *n*-dodecane. Sensitivity: $5 \cdot 10^{-12}$ A f.s.d. Smooth lines: time intervals when the detector signal was not sampled.

and at 30 msec for the two other compounds. Data acquisition proceeded at a sampling rate of 100 Hz. A representative chromatogram is given in Fig. 5, showing a moderate signal-to-noise ratio for all peaks. The second moment of each peak was estimated by fitting a Gaussian curve to the data points. Gram-Charlier series (see ref. 3) were not used, as the resulting model frequently showed oscillations caused by the noise.

The plate height curves obtained are shown in Fig. 6. Each symbol represents the average value of at least four independent measurements. The curves were compared with the theoretical equation describing the plate height of capillary columns^{3,4}:

$$H = \frac{Bf}{u_0} + C_g f u_0 + C_1 \bar{u} + D(\bar{u})^2 \quad (1)$$

where B accounts for longitudinal diffusion, C_g and C_1 represent resistance to mass transfer in the gaseous and liquid phases, respectively, D accounts for equipment contributions to the plate height, \bar{u} is the average linear carrier gas velocity, u_0 is the velocity at the column outlet and f is the pressure correction factor according to Giddings *et al.*⁵.

When the contribution of the C_1 and the D terms to the column plate height can be neglected, a simple expression for the minimum attainable plate height, H_{\min} , is found, by differentiating eqn. 1:

$$H_{\min} = 0.5 f d_c \cdot \left(\frac{1 + 6k + 11k^2}{3(1+k)^2} \right)^{\frac{1}{2}} \quad (2)$$

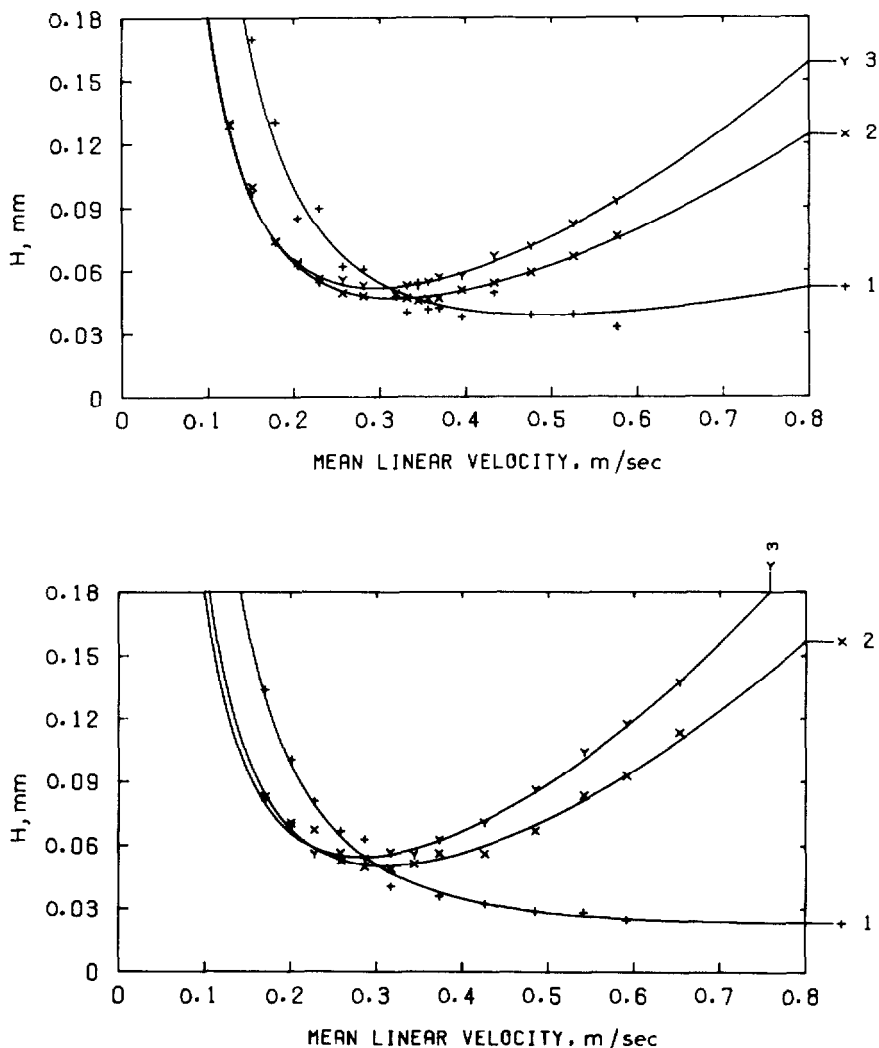

Fig. 6. H versus \bar{u} curves obtained with the fluidic logic injector with the $8 \text{ m} \times 47.1 \mu\text{m}$ I.D. borosilicate column (upper curve) and with the $10 \text{ m} \times 55.4 \mu\text{m}$ I.D. fused silica column (lower curve). Compounds studied: (1) *n*-pentane at $k = 0.05$; (2) *n*-undecane at $k = 2$; (3) *n*-dodecane at $k = 4$.

where d_c is the column inner diameter. The parameter f equals 1 for columns that are operated at a low pressure drop. When the ratio of the column inlet and outlet pressures is large, f becomes equal to its maximum value of $9/8$, resulting in a decrease of the maximum attainable column plate number by 12.5%.

Eqn. 2 must be applied with care to compounds that are virtually unretained by the stationary phase. Merle d'Aubigne *et al.*⁶ have indicated that the H_{\min} value obtained in this case is greatly dependent on the k value entered. Comparing $k = 0.00$ and $k = 0.05$, the difference in H_{\min} is calculated to be 10%.

Values for B , C_g and C_l were established by fitting eqn. 1 to the experimental

TABLE I

VALUES DERIVED FOR THE PARAMETERS OF EQN. 1 FROM THE EXPERIMENTAL PLATE HEIGHT CURVES.

Values in parentheses are standard deviations.

Parameter	Fused silica			Borosilicate glass		
	<i>n</i> -C ₅	<i>n</i> -C ₁₁	<i>n</i> -C ₁₂	<i>n</i> -C ₅	<i>n</i> -C ₁₁	<i>n</i> -C ₁₂
<i>B</i> (cm ² /sec)	0.86 (0.01)	0.49 (0.02)	0.44 (0.02)	0.92 (0.02)	0.49 (0.01)	0.48 (0.01)
<i>B</i> _{theor.}	0.88	0.58	0.55	0.94	0.62	0.59
<i>C</i> _g (μsec)	1.4 (0.2)	8.0 (0.8)	10.2 (0.7)	3.0 (0.6)	4.5 (0.5)	6.5 (0.6)
<i>C</i> _{g, theor.}	0.87	7.3	9.4	0.93	4.9	6.2
<i>C</i> ₁ (μsec)	0	16 (11)	26 (11)	0	37 (6)	39 (8)
<i>D</i> (msec ² /cm)	0.10	0.084	0.033	0.125	1.114	0.049
<i>k</i>	0.05	2.23	4.15	0.05	2.16	3.86

data by using the least-squares method. The *D* term was estimated as described by Gaspar *et al.*³. The results are given in Table I. The experimental values for *B* and *C*_g are in good agreement with theoretical values calculated from gaseous diffusion coefficients according to Fuller *et al.*⁷. The *C*₁ term is expected to be negligibly small at the film thicknesses used in our columns.⁸ However, for the borosilicate column a significant *C*₁ term is observed, possibly due to irregularities in the distribution of the stationary phase.

The influence of the chromatographic equipment on the column plate height is best evaluated from the *H* versus \bar{u} curves obtained for *n*-pentane. For the fused-silica column, 40,000 plates per metre were measured at 20 bar, corresponding to a plate height of 25.3 μm. A value of *H*_{min} = 19.7 μm is predicted by eqn. 2, assuming *k* = 0.05. The difference between the two results can be explained by postulating an extra column contribution of $\sigma^2 = 160 \text{ msec}^2$, which is very close to the time constant of the electrometer. ($\sigma^2 = 100 \text{ msec}^2$).

For the glass column, only 25,000 plates per metre (*H* = 40 μm) could be obtained at 20 bar. Eqn. 2 predicts a value of *H*_{min} = 16.8 μm, suggesting an extra column contribution of $\sigma^2 = 680 \text{ msec}^2$. This large σ may reflect flow stagnation around the column inlet, probably caused by the large ratio of outer diameter to inner diameter.

TABLE II

MEASURED (m) AND CALCULATED (c) MINIMUM PLATE HEIGHT VALUES FOR *n*-UNDECANE AND *n*-DODECANE

Parameter	Fused silica		Borosilicate glass	
	<i>n</i> -C ₁₁	<i>n</i> -C ₁₂	<i>n</i> -C ₁₁	<i>n</i> -C ₁₂
<i>H</i> _{min, m} (μm)	50.3	54.5	47.1	51.6
<i>H</i> _{min, c} (μm)	46.5	51.4	38.9	43.8
<i>N</i> _{max, m}	202,000	186,000	170,000	155,000
<i>u</i> _{opt, m} (cm/sec)	31.0	28.8	31.8	29.6

For *n*-undecane and *n*-dodecane, good agreement is observed when the experimental H_{\min} values are compared to eqn. 2 (see Table II). The coating efficiency is calculated to be 84% for the borosilicate column and 93% for the fused silica column, assuming $f = 1.12$. An optimum average carrier gas velocity of about 30 cm/sec is observed, which is in agreement with theory⁴.

When compared to a conventional 0.25 mm I.D. column having 200,000 plates, our 50 μm I.D. columns will allow a five-times faster analysis. This gain in speed is mainly due to the reduction of the plate height, as the carrier gas velocity remains almost constant owing to increased compression of the gas.

CONCLUSIONS

The fast fluidic injection system operated at pressures between 4 and 25 bars is able to produce symmetrical injection profiles of 5 msec standard deviation. The extra-column effects due to band broadening arising from the injection can therefore be neglected. The time constant of the electrometer is then the primary source of instrumental band broadening effects, but it can be estimated with good accuracy.

The chromatographic device described in this work allows the precise analysis of H versus \bar{u} curves in high-speed capillary gas chromatography. The coefficients of the plate height equation derived from the experimental data, are in good agreement with the Golay-Giddings theory. Good coating efficiencies were found for both small diameter columns studied.

ACKNOWLEDGEMENTS

We thank Mr. G. Preau and Mr. B. Vermeer for expert technical assistance, Dr. G. Gaspar for stimulating discussions and helpful advice and Mr. E. Dawes, Scientific Glass Engineering, Melbourne, Australia, for the generous gift of the 50 μm I.D. fused silica capillary tubing.

REFERENCES

- 1 G. Gaspar, P. Arpino and G. Guiochon, *J. Chromatogr. Sci.*, 15 (1977) 256.
- 2 G. Gaspar, J. Olivo and G. Guiochon, *Chromatographia*, 11 (1978) 321.
- 3 G. Gaspar, R. Annino, C. Vidal-Madjar and G. Guiochon, *Anal. Chem.*, 50 (1978) 1512.
- 4 C.P.M. Schutjes, E.A. Vermeer, J.A. Rijks and C.A. Cramers, *J. Chromatogr.*, 253 (1982) 1.
- 5 J.C. Giddings, S.L. Seager, L.R. Stucki and G.H. Stewart, *Anal. Chem.*, 32 (1960) 867.
- 6 J. Merle d'Aubigne, M. Jacques and G. Guiochon, *Chromatographia*, 2 (1969) 98.
- 7 E.N. Fuller, P.D. Schettler and J.C. Giddings, *Ind. Eng. Chem.*, 58 (1966) 19.
- 8 C.A. Cramers, C.E. van Tilburg, C.P.M. Schutjes, J.A. Rijks, G.A.F.M. Rutten and R. de Nijs, *J. Chromatogr.*, 279 (1983) 83.